

OMICRON

TOYOTA

3S-GE Rev3

The text shown is machined into the face (rather than raised above it), and is shown with a standard type face for illustrative purposes only. The text can be adjusted to suit available tooling, or can be omitted altogether to reduce costs.

DRAWN Tristan Cliffe		15/10/2008		Omicron Engineering Ltd.	
CHECKED					
QA				TITLE  Toyota 3S-GE Cam Cover	
MFG					
APPROVED					
MATERIAL Aluminium		SIZE A4		PART NO Cam Cover1	
		SCALE 1 : 2		REVISION REV	
		MASS 3.77 kg		SHEET 1 OF 9	

A

A

B

B

C

C

D

D

1

2

3

4

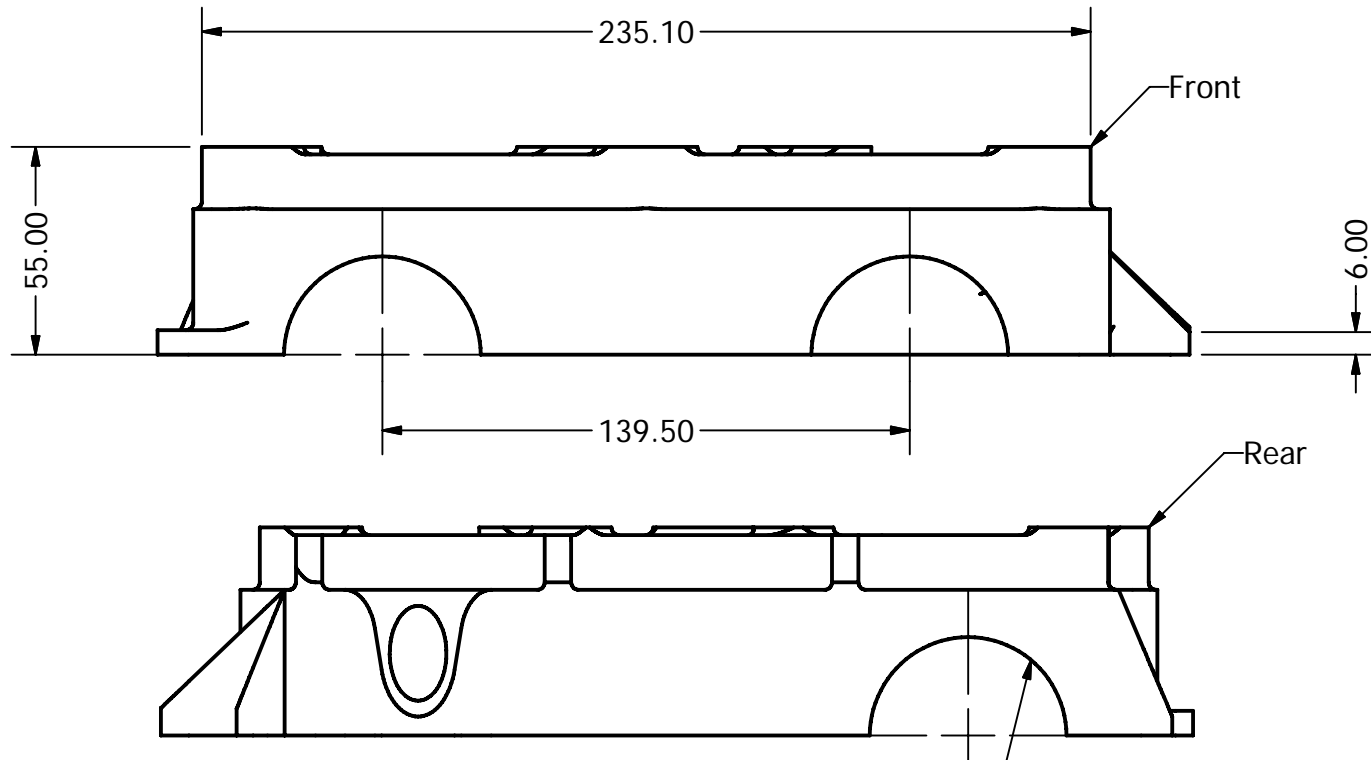

These hold an o-ring that seals against the cast camshaft caps. Therefore finish and quality are not so important. Maching from below with a ball nosed cutter would be acceptable rather than a third operation with the cover remounted on its end.

DRAWN Tristan Cliffe		15/10/2008		Omicron Engineering Ltd.	
CHECKED					
QA				TITLE	
MFG				Toyota 3S-GE Cam Cover	
APPROVED					
MATERIAL Aluminium					
		SIZE A4	PART NO Cam Cover1	REV	
		SCALE 1 : 2	MASS 3.77 kg	SHEET 2 OF 9	

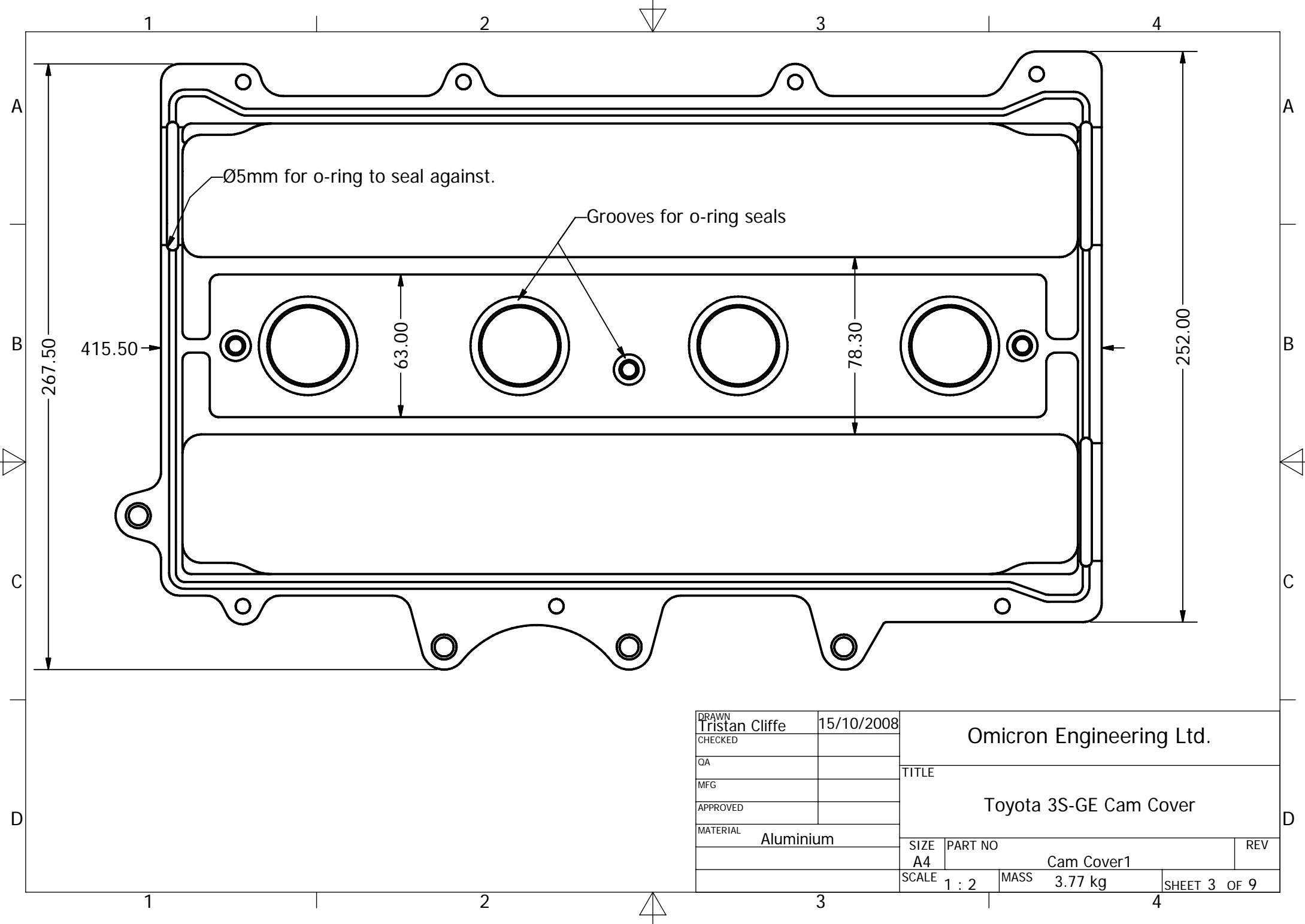

Ø5mm for o-ring to seal against.

Grooves for o-ring seals

415.50

63.00

78.30

252.00

DRAWN Tristan Cliffe		15/10/2008		Omicron Engineering Ltd.	
CHECKED					
QA				TITLE  Toyota 3S-GE Cam Cover	
MFG					
APPROVED					
MATERIAL Aluminium		SIZE A4		PART NO Cam Cover1	
		SCALE 1 : 2		REV	
		MASS 3.77 kg		SHEET 3 OF 9	

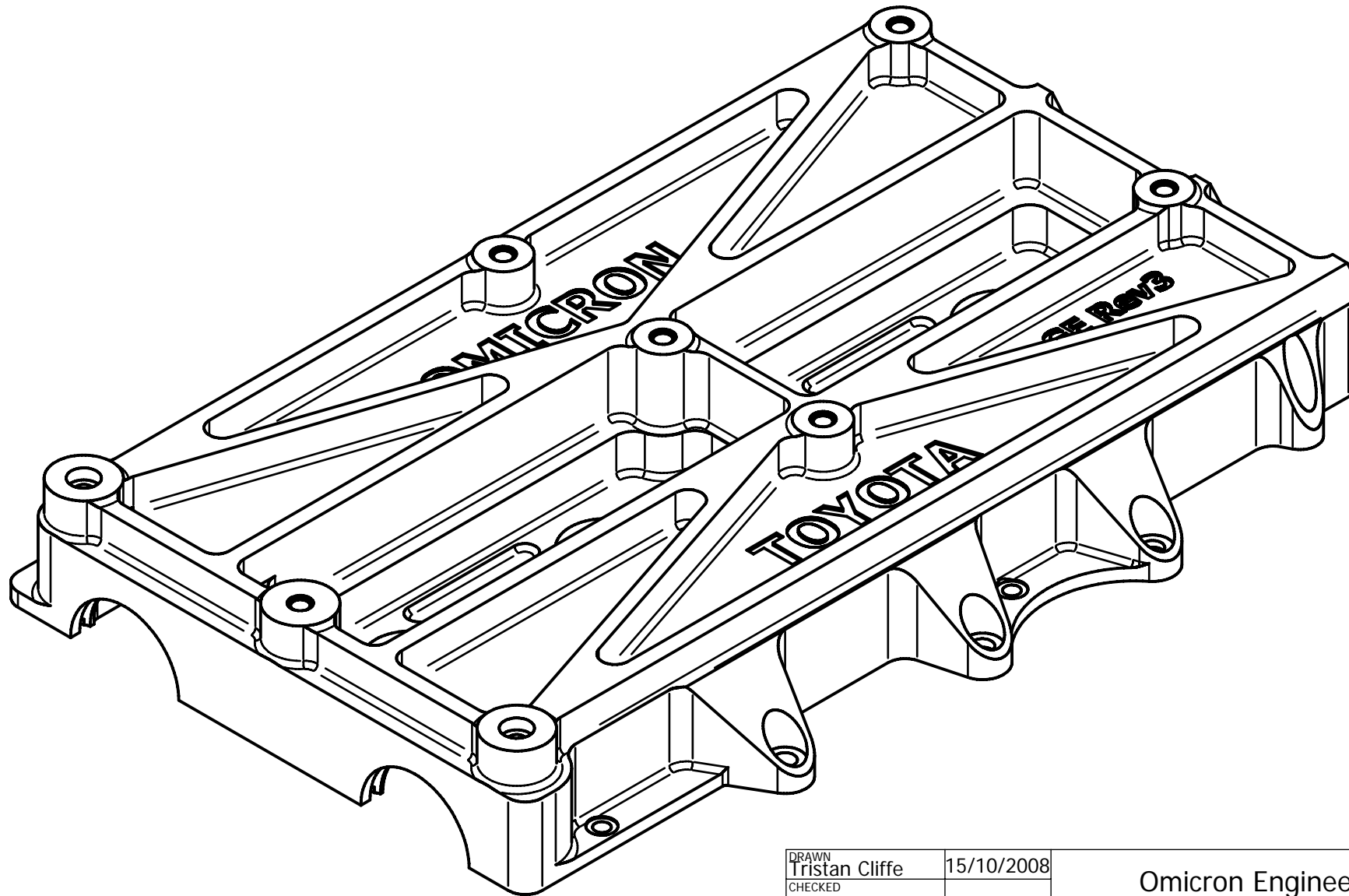

DRAWN Tristan Cliffe		15/10/2008		Omicron Engineering Ltd.	
CHECKED					
QA				TITLE Toyota 3S-GE Cam Cover	
MFG					
APPROVED					
MATERIAL Aluminium		SIZE A4		PART NO Cam Cover1	
		SCALE 1 : 2		REVISION REV	
		MASS 3.77 kg		SHEET 4 OF 9	

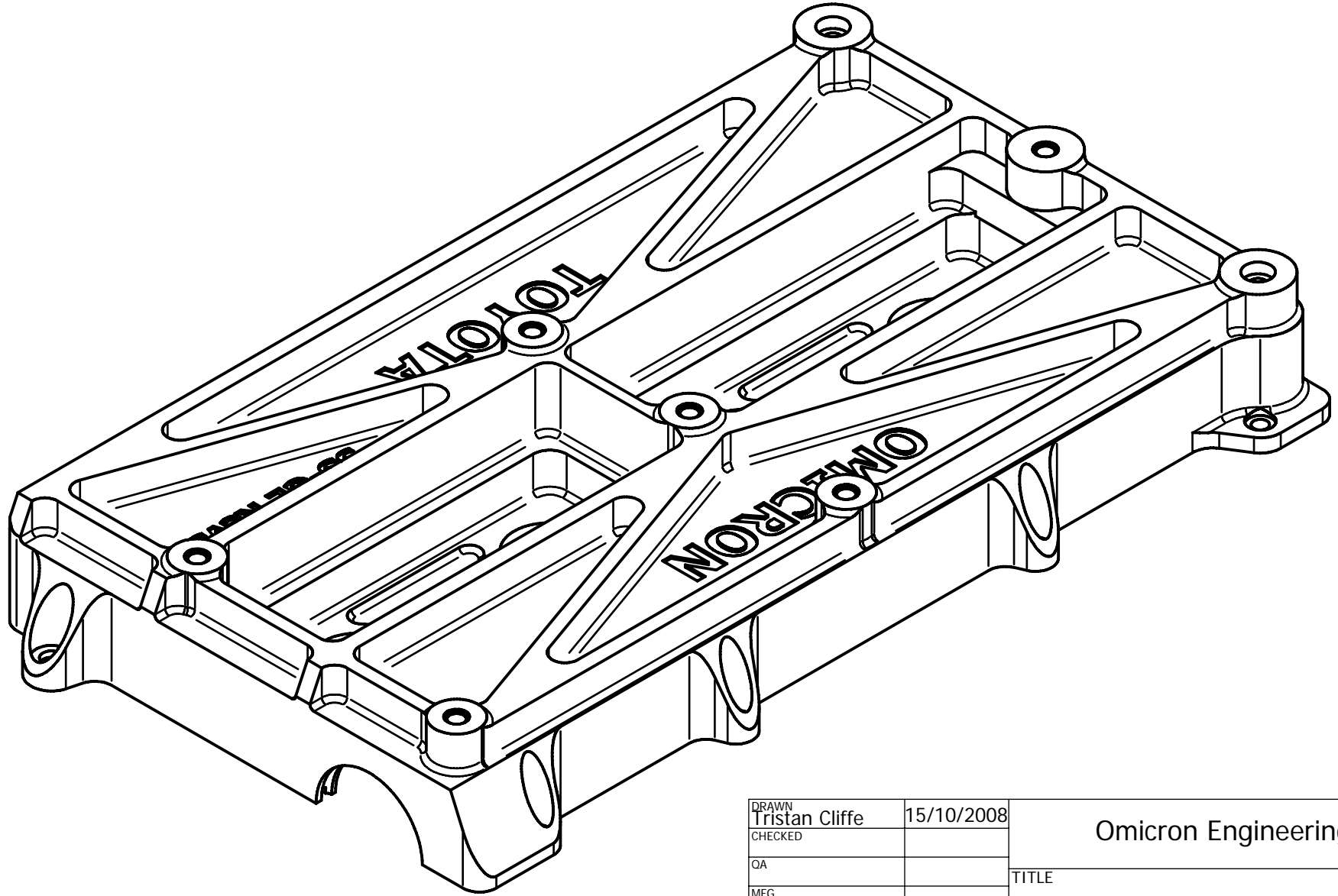

DRAWN Tristan Cliffe		15/10/2008		Omicron Engineering Ltd.	
CHECKED					
QA				TITLE Toyota 3S-GE Cam Cover	
MFG					
APPROVED					
MATERIAL Aluminium				SIZE A4	
		PART NO Cam Cover1		REV	
		SCALE 1 : 2		MASS 3.77 kg	
				SHEET 5 OF 9	

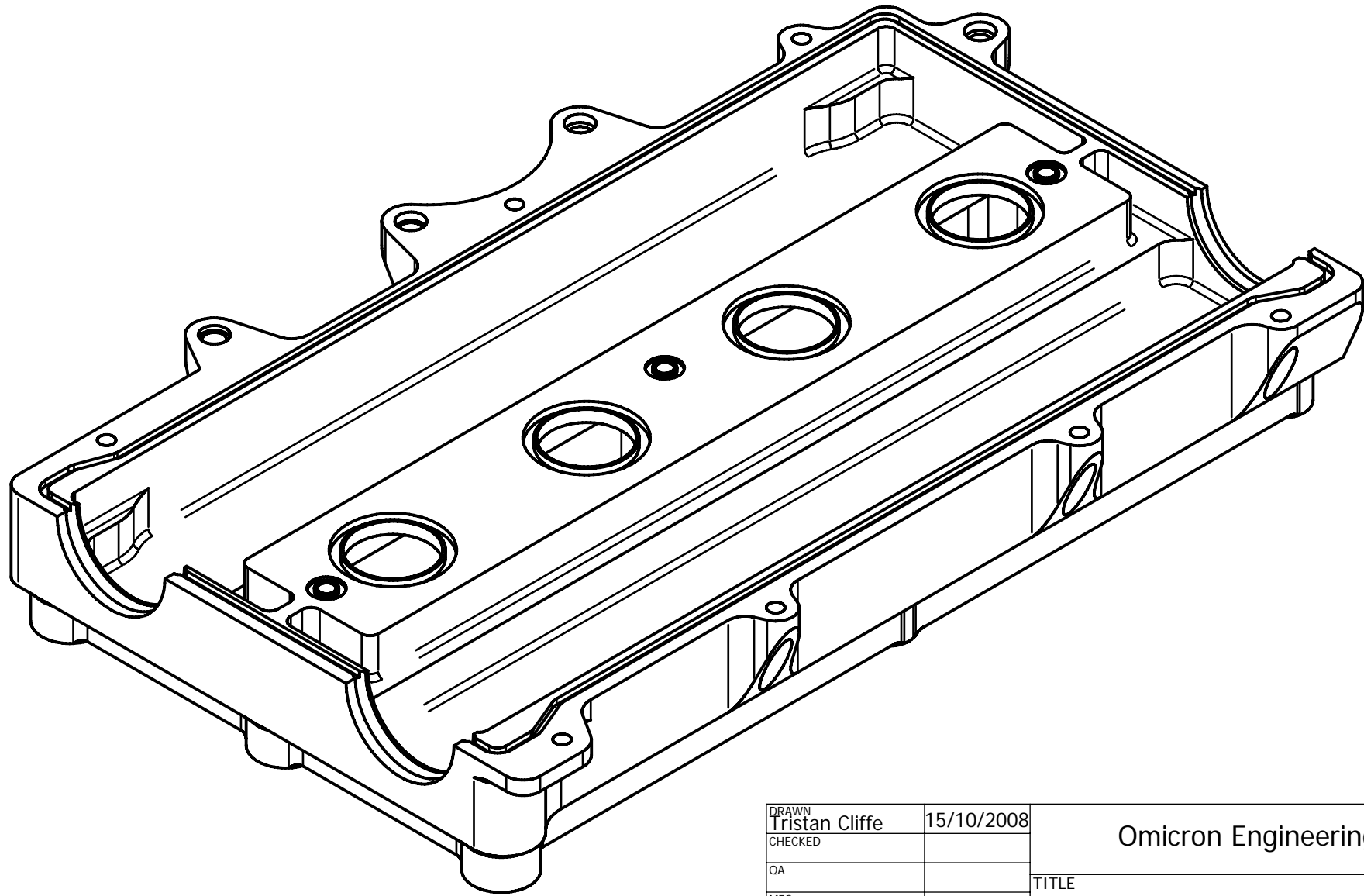

DRAWN Tristan Cliffe		15/10/2008		Omicron Engineering Ltd.	
CHECKED					
QA				TITLE Toyota 3S-GE Cam Cover	
MFG					
APPROVED					
MATERIAL Aluminium				SIZE A4	
		PART NO Cam Cover1		REV	
		SCALE 1 : 2		MASS 3.77 kg	
				SHEET 6 OF 9	

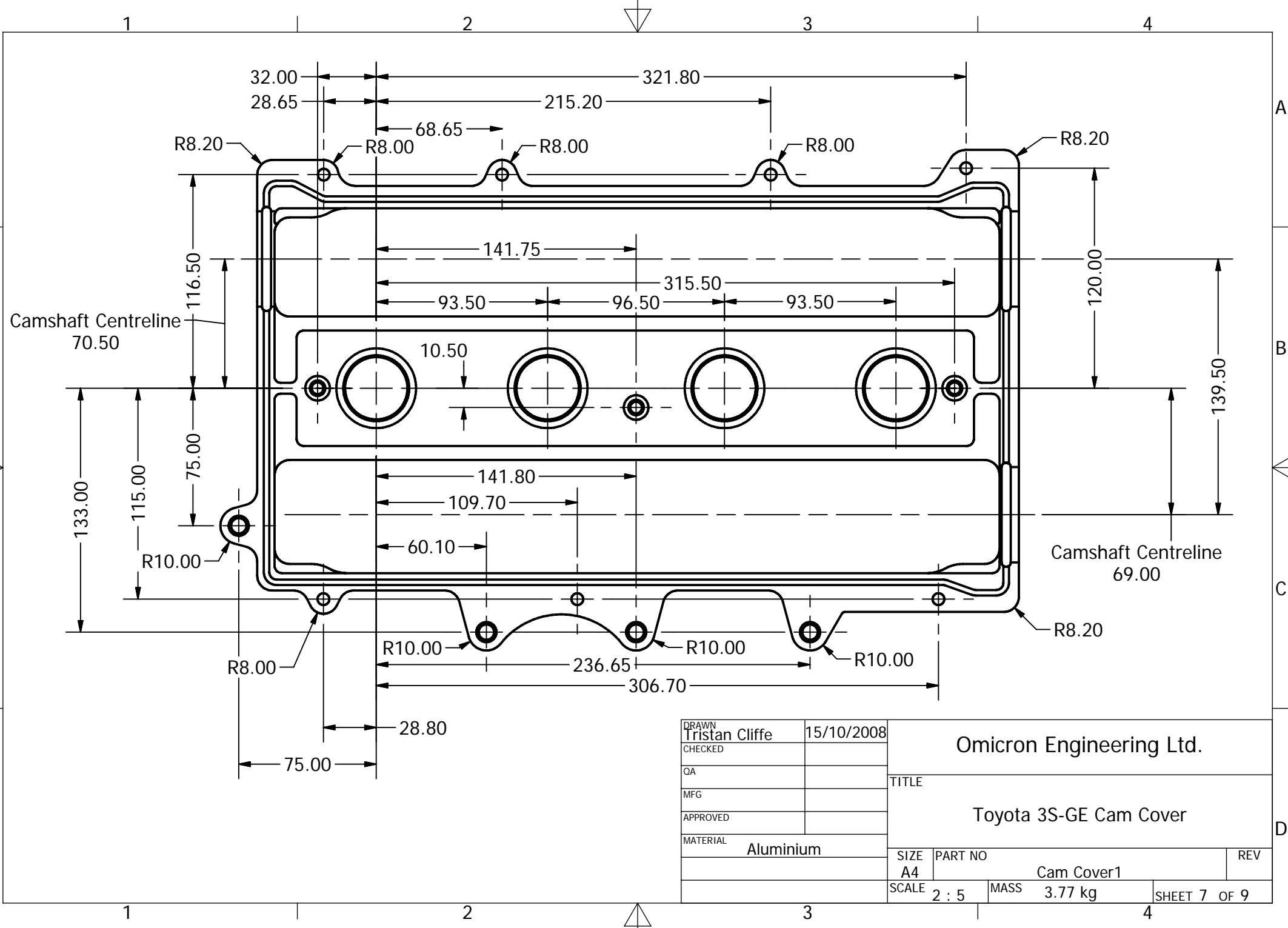

DRAWN Tristan Cliffe		15/10/2008		Omicron Engineering Ltd.	
CHECKED					
QA				TITLE Toyota 3S-GE Cam Cover	
MFG					
APPROVED				SIZE A4	
MATERIAL Aluminium					
		PART NO Cam Cover1		REV	
		SCALE 2 : 5		MASS 3.77 kg	
				SHEET 7 OF 9	

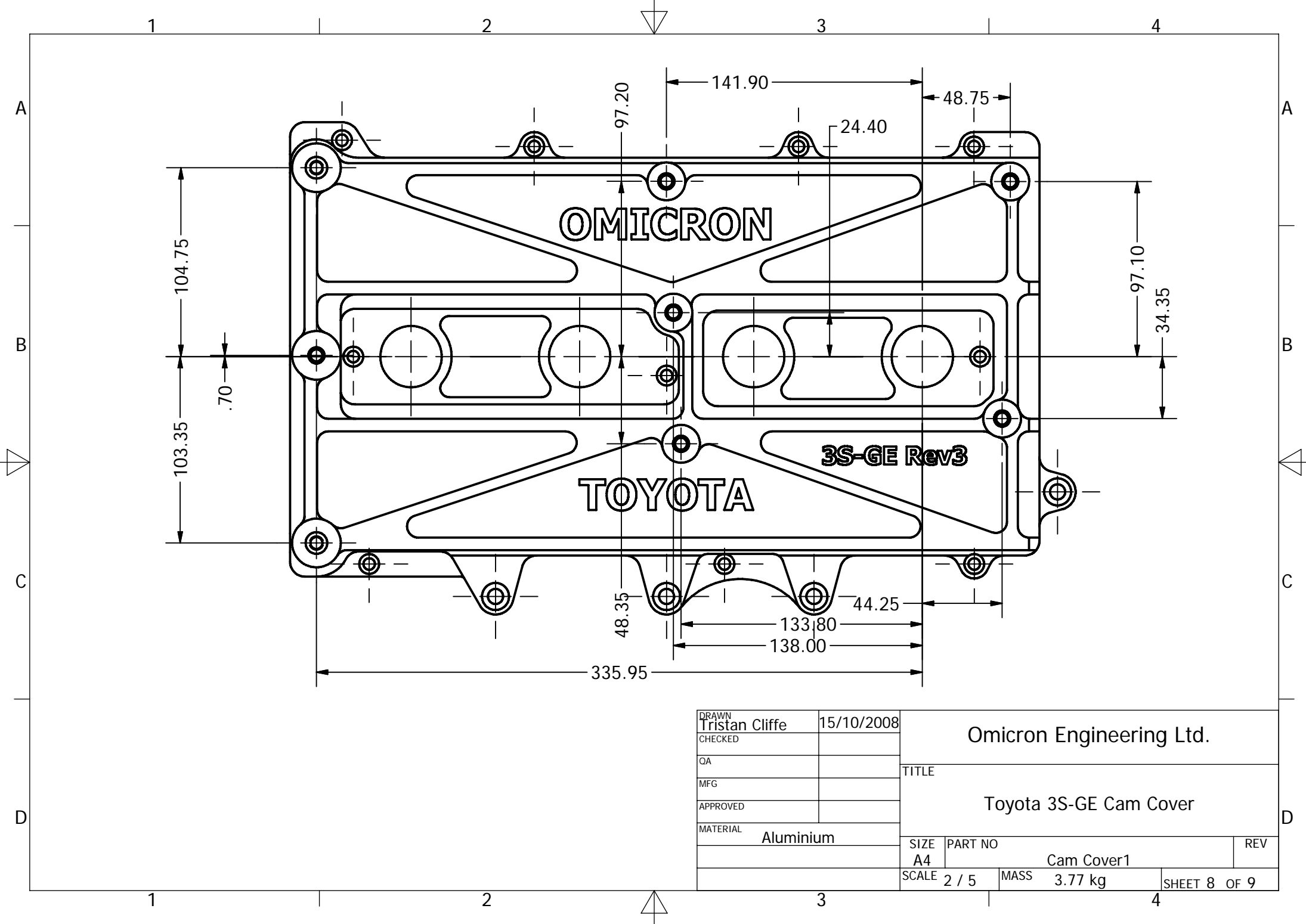

OMICRON

TOYOTA

3S-GE Rev3

DRAWN Tristan Cliffe		15/10/2008		Omicron Engineering Ltd.	
CHECKED					
QA				TITLE Toyota 3S-GE Cam Cover	
MFG					
APPROVED					
MATERIAL Aluminium				SIZE A4	
		PART NO Cam Cover1		REV	
SCALE 2 / 5		MASS 3.77 kg		SHEET 8 OF 9	



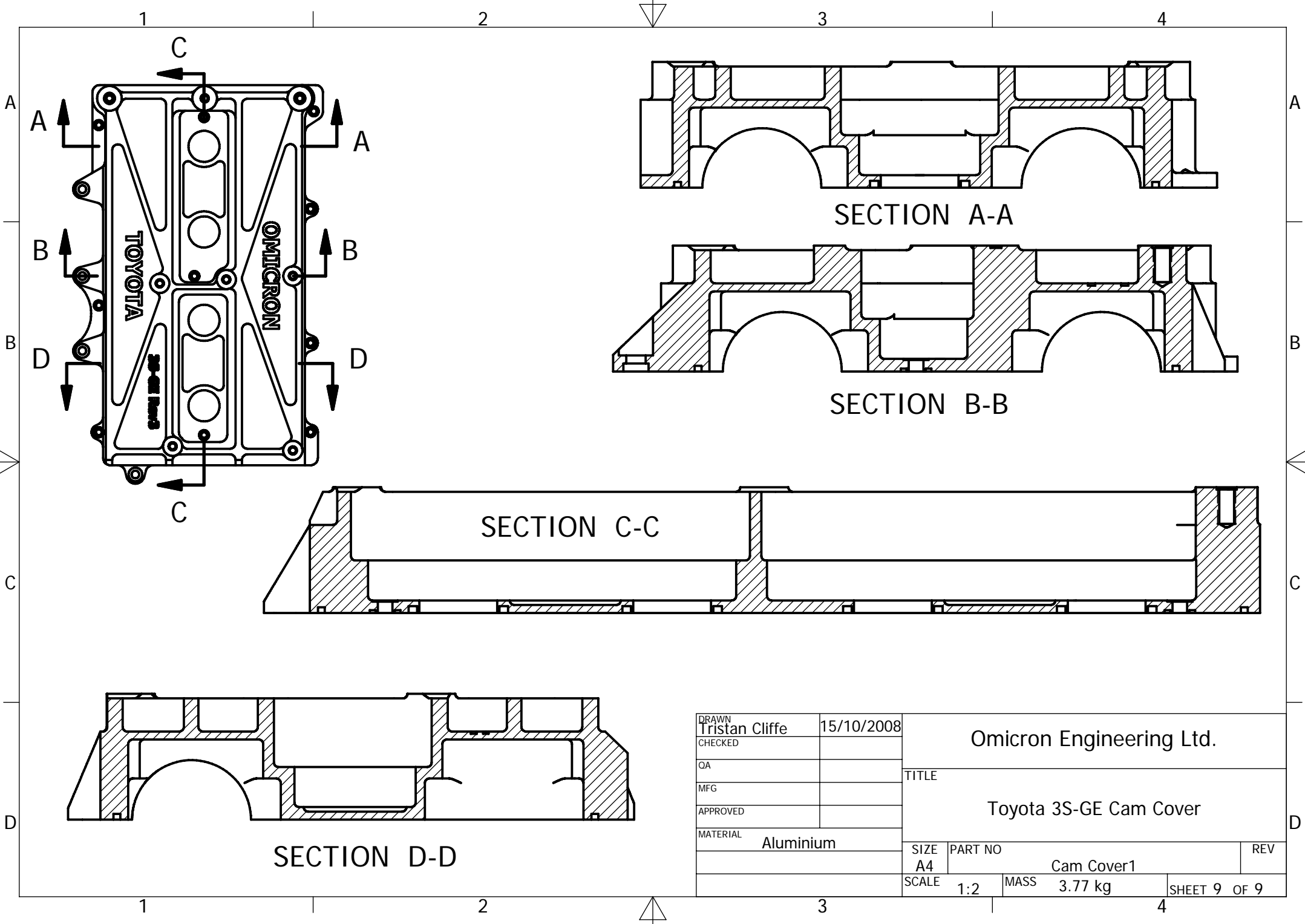

SECTION A-A

SECTION B-B

SECTION C-C

SECTION D-D

DRAWN Tristan Cliffe		15/10/2008		Omicron Engineering Ltd.	
CHECKED				TITLE	
QA				Toyota 3S-GE Cam Cover	
MFG				REV	
APPROVED				SIZE PART NO	
MATERIAL Aluminium		A4		Cam Cover1	
SCALE 1:2		MASS 3.77 kg		SHEET 9 OF 9	